

Powering a Gumstix

The Gumstix can be powered through an expansion board connected to the 60 pin Hirose connector (basix) or the 92 pin Hirose connector (connex). The power input is named V_BATT on these connectors. There are coaxial power connectors on all of the Gumstix expansion boards. If you are using a connex Gumstix, it is possible to connect expansion boards to both the 60 pin and 92 pin connectors and it is possible to power the system from either expansion board. If you are using a Robostix expansion board, you must use the power connector on the Robostix.

Power wiring

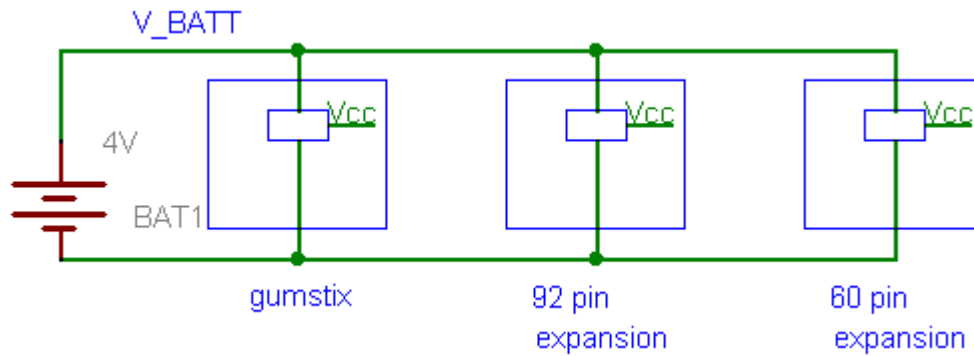

The maximum V_BATT input is 6.0V

With a Robostix you must connect power to the Robostix and the power must be between 5-6V because the Robostix runs at 5V and generates V_BATT for the rest of the system.

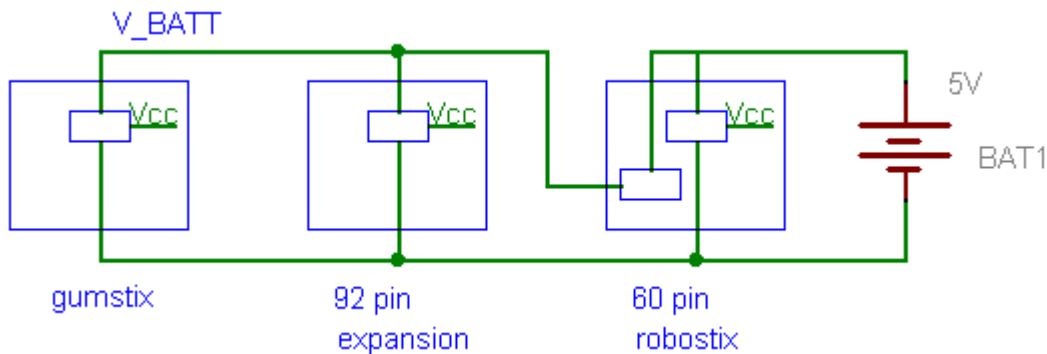

High current loads

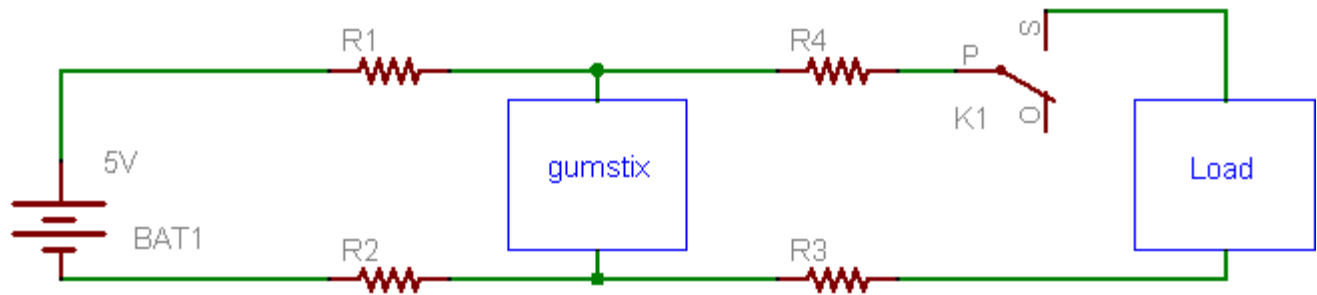

Figure 1

Resistors R1, R2, R3, and R4 are not discrete resistors. They are drawn here to help you visualize an important issue. As a demonstration, let's use wire wrap wire to connect a battery to the gumstix and a switched load. Wire wrap wire is 10 mil diameter and has a resistance of 0.1 ohms per foot. An application of Ohm's law gives the voltage across each resistor (wire). If the load draws 1A, the voltage drop across R1 is 100mV per foot. Many loads aren't purely resistive. There will be a significant difference between the turn on current and the steady state current.

The voltage input to the gumstix must be greater than the drop out voltage of its on board regulator. This depends on the gumstix current demand, which depends on what the gumstix is doing. Booting requires significantly more current than the console idle loop. Bluetooth and other options also use more current. When the supply to the gumstix drops below about 3.4V, the CPU resets.

Batteries have limited current capability. Imagine R1 and R2 as internal to the battery. The more current you draw, the lower the battery terminal voltage.

The easiest way to deal with high current loads is to use a separate battery or supply for the gumstix and for the load. These supplies need a common reference which is usually achieved by wiring the supply's grounds together.

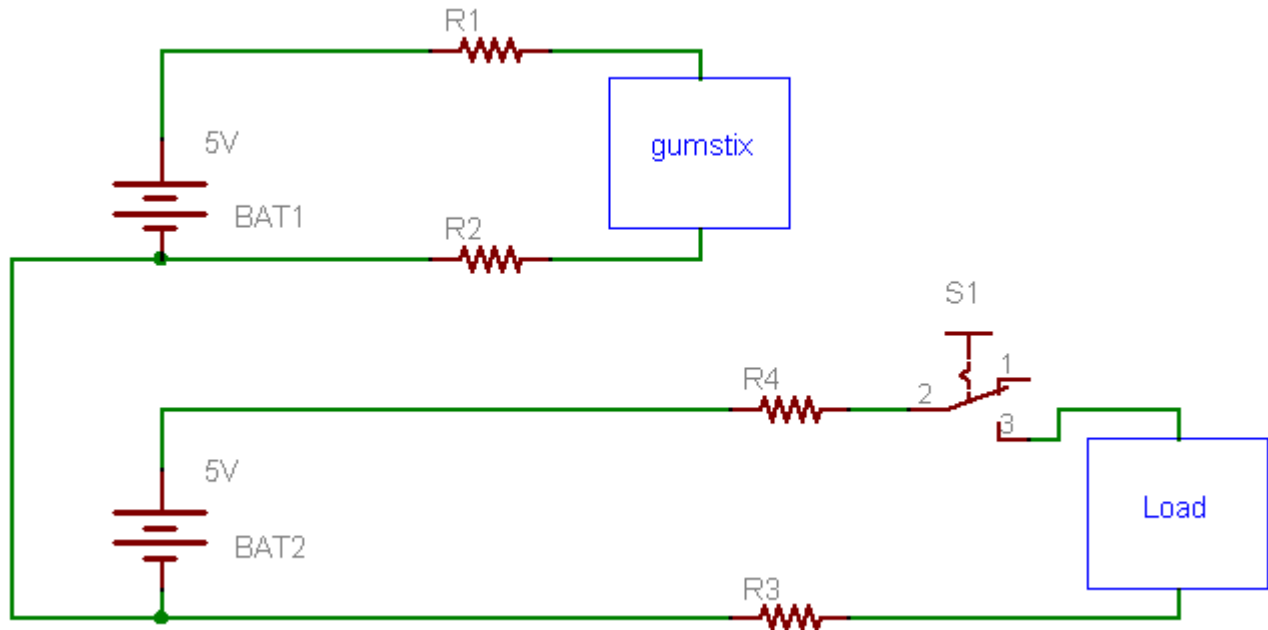

Figure 2

Note that BAT2 can be 12V or whatever makes the most sense for your load. If the load can be powered by the same supply as the gumstix, you would wire like this:

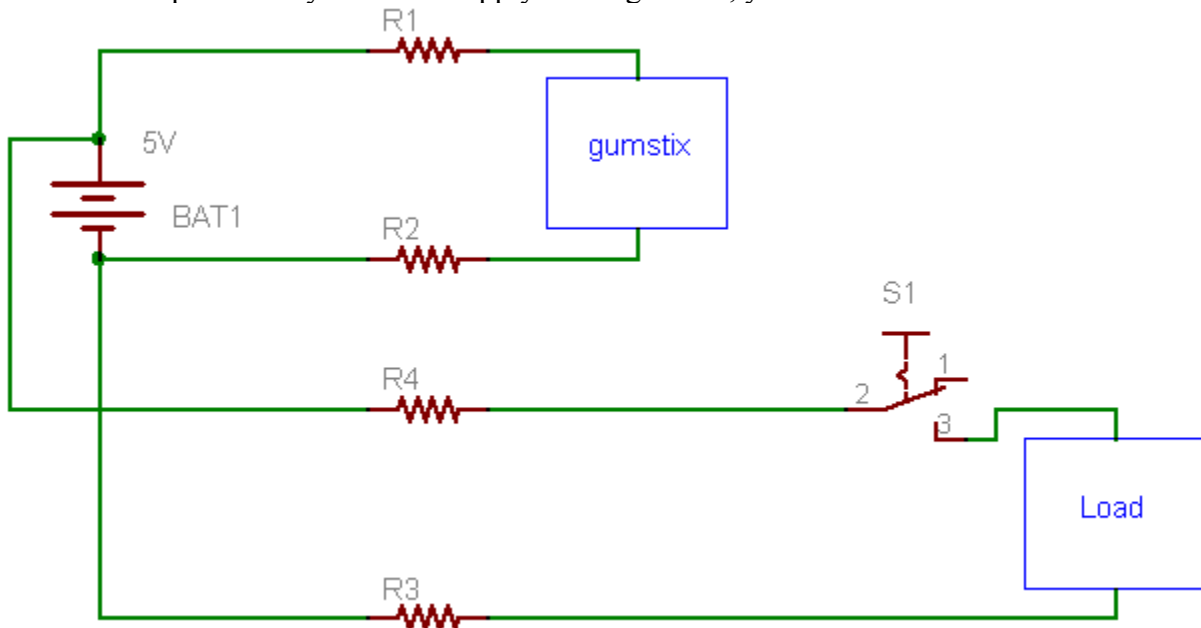

Figure 3